

REVISIONS

| REVISION | DESCRIPTION | APPROVED | DATE |
|----------|----------------------|-------------|----------|
| - | Initial Release | Luis Vargas | 6/5/2008 |
| A | Updated part numbers | Luis Vargas | 1/9/09 |

GENERAL RELEASE DOCUMENT
CONSULT FACTORY FOR CURRENT REVISION

50MHz TCXO ,Vcc=12v,+25°C
9/17/08

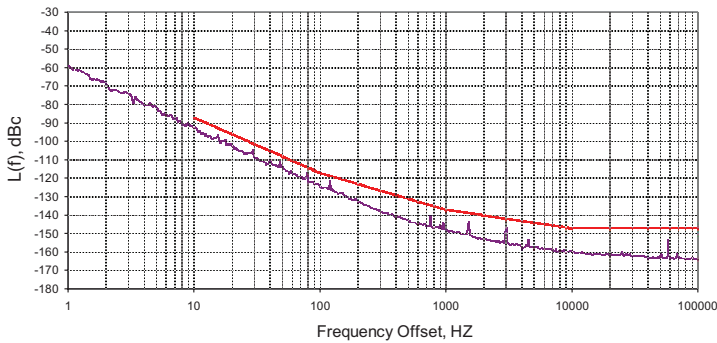

Aging Data

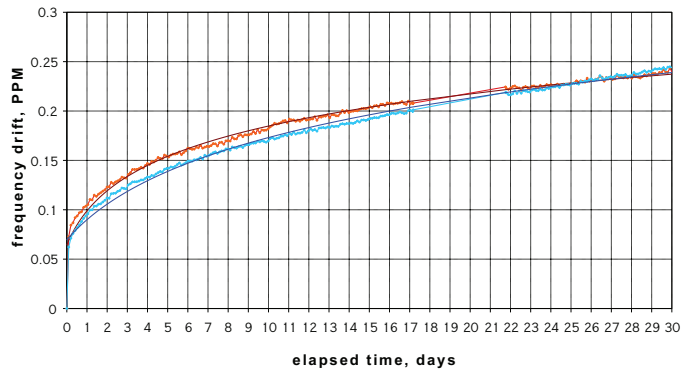

Example 1 of Temperature Stability

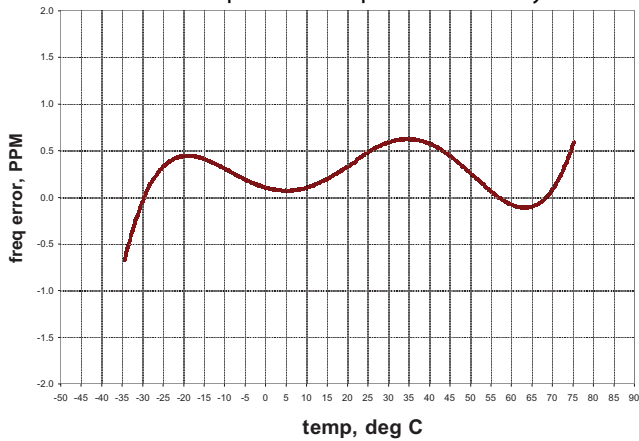

Example 2 of Temperature Stability

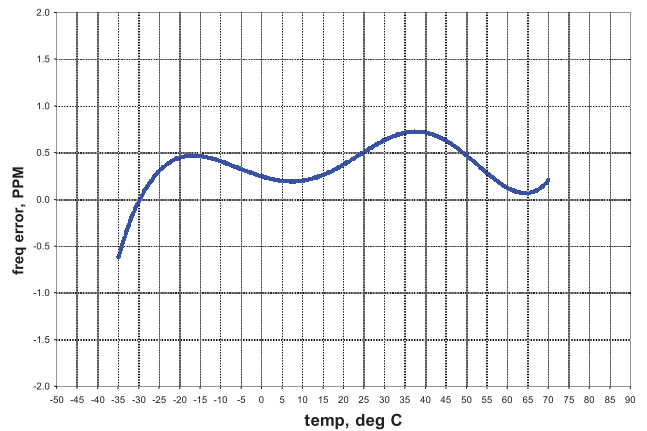

SPECIFICATION CONTROL DRAWING

| | | | | | |
|---|---------------------------------|----------------------|---|---------------------------|--------------------------|
| UNLESS OTHERWISE SPECIFIED, DIMENSIONS ARE IN INCHES. TOLERANCES: 3 PLACE DECIMAL = .005 2 PLACE DECIMAL = .02 1 PLACE DECIMAL = .1 FRACTIONS = ± 1/16 ANGLES = 2 DEGREES | PREPARED BY: Luis Vargas | DATE 6/5/08 | Q-TECH CORPORATION 10150 W. JEFFERSON BLVD. CULVER CITY, CA 90232-3510 | | |
| | CHECKED BY: QUALITY | DATE | LOW PROFILE 24 PIN Flat-Pack HYBRID CRYSTAL OSCILLATOR, TCXO, CLASS S, Standard Design For HCMOS up to 90MHz | | |
| RELEASED BY: DOCUMENT CONTROL | APPROVED BY: ENGINEERING | DATE | DRAWING NO.: QT811 and QT812 Square-Wave | | REVISION A |
| | | SCALE NONE | SIZE A | CAGE CODE 51774 | SHEET 1 of 8 |

1.0 SCOPE

This specification establishes the detail requirements for low profile hybrid, hermetically sealed, HCMOS output temperature compensated crystal oscillators (TCXO) for use in space flight missions.

2.0 APPLICABLE DOCUMENTS

The following documents of the latest issue form a part of this drawing to the extent specified herein.

2.1 Specifications and Standards

| SPECIFICATIONS | |
|----------------|---|
| MILITARY | |
| MIL-S-19500 | Semiconductor Devices, General Specification For |
| MIL-PRF-55310 | Crystal Oscillators, General Specification For |
| MIL-PRF-38535 | Integrated Circuits, (Microcircuits) Manufacturing, General Specification For |
| MIL-PRF-38534 | Hybrid Microcircuits, General Specification For |
| STANDARDS | |
| MILITARY | |
| MIL-STD-202 | Test Methods for Electronic and Electrical Component Parts |
| MIL-STD-883 | Test Methods and Procedures for Microelectronics |
| MIL-STD-1686 | Electrostatic Discharge Control Program for Protection of Electrical and Electronics Parts, Assemblies and Equipment. |

2.2 Conflicting Requirements

In the event of conflict between requirements of this specification and other requirements of the applicable detail drawing, the precedence in which requirements shall govern, in descending order, is as follows:

- a) Applicable Customer purchase order.
- b) Applicable detail drawing.
- c) This specification.
- d) Other specifications or standards referenced in 2.1 herein.

2.3 Customer Purchase Order Special Requirements

Additional special requirements shall be specified in the applicable Customer purchase order when additional requirements or modifications specified herein are needed for compliance to special program or product line requirements.

3.0 PERFORMANCE REQUIREMENTS

3.1 General Definition

The TCXO is a high reliability signal generator that provides a square-wave output. The TCXO has been designed to operate in a spaceflight environment with an expected lifetime in excess of 15 years. Lifetime is defined as the sum of operational and storage environments.

Q-TECH Corporation
10150 W. Jefferson Blvd.
Culver City, CA 90232

SIZE
A

CAGE NO.
51774

QT811 and QT812 Square-Wave

Sheet 2 of 8

REV.

A

3.1.1 Electrical Characteristics

| PARAMETER | SYMBOL | CONDITIONS | VALUE | UNIT | |
|--|--------------|---|---|--|--------|
| Frequency Nom. | fo | - | 2. to 90 | MHz | |
| Supply voltage, Nom. | Vs | Vs±5% | <i>See part number generation table</i> | V | |
| Input Current, max. | Is | Vs, nom. / Ta=+25°C | 50 | mA | |
| Freq. stability vs. temperature (including ±5% Load Change and ±5% Input Voltage change) | Δf/fc (Ta) | <i>Contact factory for other options available</i> | <i>See part number generation table</i> | ppm | |
| Electrical Frequency Adjustment Min. (when specified) | Δf/fo (ΔVcc) | ±5 PPM <u>Two options:</u> 1) via an external select-at-test resistor connected from Pin 1 to Ground 2) Via External tuning voltage | ±5.0 | ppm | |
| Aging Max | Δf/fo | over 10 year (first year ≤ 1 ppm) | ±5.0 | ppm | |
| Freq. stability vs. Vacuum | Δf/fo | Met by design, not tested | ±0.2 | ppm | |
| Short term stability | Δf/fc(Δt) | Δt=1sec. (Allan variance) | 0.001 | ppm | |
| RF Output | | <i>Contact factory for other options available</i> | 30 to 70 3rd | 70.1 to 90 3 rd X | MHz |
| Output | VOH / VOL | load=15pF, Vcc=nom. | 0.9•Vcc / 0.1•Vcc | V | |
| Duty cycle | DC | load=15pF/ @50%Vcc, Ta=+25°C | <i>See part number generation table</i> | % | |
| Rise- / fall time | tr / tf | 20%~80% Vout, 80%~20% Vout | .5...7 (see note A) | nSec | |
| Load | | | 15 | pF | |
| Phase noise @ freq. offset | £ (Δf) | Δf=10Hz | -75 | <i>Contact factory for other options available</i> | dBc/Hz |
| | £ (Δf) | Δf=100Hz | -105 | | dBc/Hz |
| | £ (Δf) | Δf=1kHz | -130 | | dBc/Hz |
| | £ (Δf) | Δf=10kHz | -140 | | dBc/Hz |
| | £ (Δf) | Δf=100kHz | -140 | | dBc/Hz |

A: **Supply Current, rise & fall time are frequency dependent**

3.2 Absolute Maximum Rating

| | |
|--|-----------------|
| Supply Voltage | 0 to +6.0 VDC |
| DC Input Current | 50 mA maximum |
| Storage Temperature range | -62°C to +125°C |
| Lead Temperature (Soldering, 10 seconds) | 300°C |

3.2.1 Physical Characteristics

3.2.1.1 Dimensions - The TCXO outline dimensions and terminal connections shall be as shown in Figure 1 herein.

3.2.1.2 Weight - The TCXO shall weigh less than or equal to 15 grams.

3.2.1.3 Materials - The TCXO package body and lead finish shall be gold in accordance with MIL-PRF-38534.

| | | | | |
|--|------------------|--------------------------|------------------------------------|--------------|
| Q-TECH Corporation 10150 W. Jefferson Blvd. Culver City, CA 90232 | SIZE A | CAGE NO. 51774 | QT811 and QT812 Square-Wave | REV. |
| | | | Sheet 3 of 8 | A |

3.2.2 Environmental Conditions

| | |
|-------------------------------------|--|
| Sine Vibration | MIL-STD-202, Method 204, TC "D" |
| Random Vibration | MIL-STD-202, Method 214 TC "I-K" (15 minutes per axis) |
| Shock | MIL-STD-202, Method 213, TC "F" |
| Acceleration | MIL-STD-883, Method 2001, TC "A" |
| Altitude | 50,000 feet minimum to deep space |
| Radiation | Radiation testing is not performed, but these TCXOs have been acceptable for use in environments up to 100K rads by analysis of the components used. Bipolar semiconductors are employed in combination with a CMOS microcircuit in this part and shall be from a wafer proven to be radiation tolerant to 100 kRad (Si) total ionizing dose. This device is specified to be single event latchup free for LET up to 93 MeV-cm ² /mg.. A copy of the parts list and materials can be provided for review. |
| Electrostatic Discharge Sensitivity | The TCXO supplied to this drawing shall be considered to be electrostatic discharge sensitive and require further protection and shall use one of the packaging requirements in accordance with MIL-PRF-38534, Category A, Section 5.3.2.4 Transportability. The TCXO shall be capable of being transported by air, ship or road when packaged in a suitable container. |

3.3 Design and Construction

The design and construction of the crystal oscillator shall be as specified herein. As a minimum, the oscillators shall meet the design and construction requirements of MIL-PRF-55310, except element evaluation shall be as specified in 3.3.1.

| Operation | |
|---|---|
| Design, Construction & Component Screen (see 3.3.2) | MIL-PRF-55310 Class S |
| Workmanship | M883, Method 2017 for Class S |
| Screening | MIL-PRF-55310 Class S |
| Non-Destruct Wire Bond Pull | 100%, M883, Method 2023 (2.4 grams) |
| Internal Visual | MIL-STD-883, methods 2017 & 2032 condition K (class S). During the time interval between final internal visual inspection and preparation for sealing, hybrid crystal oscillators shall be stored in a dry, controlled environment as defined in MIL-STD-883, method 2017 or in a vacuum bake oven. |
| Stabilization Bake | 48 hrs minimum @ +150 C M883, Method 1008 TC B |
| Thermal Shock | M883, Method 1011, TC A |
| Temperature Cycling | M883, Method 1010, TC B |
| Constant Acceleration | M883, Method 2001, TC A (5000 gs, Y1 Axis only) |
| Seal Test (fine & gross) | 100% Method 1014, (TC A1 for fine leak and TC C for gross leak) |
| PIND | M883, Method 2020, TC B |
| Electrical Test | Frequency, Output levels, Input Current@ +25 C |
| Burn-In (Powered with load) | +125 C for 240 hours |
| Electrical Test | Frequency, Output levels, Input Current @ +25°C & Temp Extremes listed on the Electrical Specification |
| Radiographic | M883, Method 2012 class S |
| Group A | 100% |
| Group B (30 day Aging @ +70 C) | 100% |
| External visual | 883 Method 2009 |

Q-TECH Corporation
10150 W. Jefferson Blvd.
Culver City, CA 90232

SIZE
A

CAGE NO.
51774

QT811 and QT812 Square-Wave

Sheet 4 of 8

REV.

A

3.3.1 All piece parts shall be derived from lots that meet the element evaluation requirements of MIL-PRF-38534, Class K, with the following exceptions:

Active elements

- a) Visual inspection of silicon on sapphire microcircuits. Semicircular crack(s) or multiple adjacent cracks, not in the active area, starting and terminating at the edge of the die are acceptable. Attached (chip in place) sapphire is nonconductive material and shall not be considered as foreign material and will be considered as nonconductive material for all inspection criteria.
- b) Subgroup 4, Scanning Electron Microscope (SEM) inspection. The manufacturer may allow the die distributor, at his option, to select two (2) dice from a waffle pack (containing a maximum quantity of 100 die), visually inspect for the worst case metallization of the 2 dice, and take SEM photographs of the worst case.
- c) Subgroup 5 radiation tests. Subgroup 5 radiation tests are not required unless otherwise specified in the detail purchase order.

3.3.2 Processes - Processes used for manufacturing the TCXO are selected on the basis of their ability to meet the quality requirements for space High Reliability manufacturing. Travelers or Process Cards are used in the manufacturing and testing of all of the TCXO Series, and might be available for customer review. Copies of these Travelers can be provided with the TCXOs at time of shipment, if so specified on the purchase order.

3.3.3 Interchangeability - Each TCXO shall be interchangeable without using a special selection process.

3.3.4 Product Marking - Each unit shall be permanently marked with the manufacturer's name or symbol, part number, lot date code number, and serial number. The unit shall be marked with the outline of an equilateral triangle near pin 1 to show that it contains devices which are sensitive to electrostatic discharge.

3.4 Parts Program

Devices delivered to this specification represent the standardized Parts, Materials and Processes (PMP) Program developed, implemented and certified for advanced applications and extended environments.

3.4.1 Quartz Crystal Resonator - The crystal resonator used shall be constructed using premium synthetic swept Quartz and procured to Q-TECH SCD. For the Engineering models, non-swept quartz may be used.

3.5 Traceability Requirements

Material, element and process traceability requirements shall be as specified by MIL-PRF-38534 for Class K hybrids.

3.6 Data

3.6.1. Design Documentation. When required by the purchase order, design, topography, process and flow charts for all assembly/inspection and test operation for devices to be supplied under this specification on the initial procurement shall be established and shall be available in-plant for review by the procuring activity upon request. This design documentation shall be sufficient to depict the physical and electrical construction of the devices supplied under the specification and shall be traceable to the specific parts, drawings or part type numbers to which it applies, and to the production lot(s) and inspection lot codes under which devices are manufactured and tested so that revisions can be identified.

| | | | | |
|--|------------------|--------------------------|------------------------------------|----------|
| Q-TECH Corporation 10150 W. Jefferson Blvd. Culver City, CA 90232 | SIZE A | CAGE NO. 51774 | QT811 and QT812 Square-Wave | REV. |
| | | | Sheet 5 of 8 | A |

3.6.2. Technical Data Package. When required by the purchase order, the following design documentation and information is deliverable 30 days prior to the start of production. The Technical Data Package shall consist of the following:

- a) Assembly drawing(s).
- b) All electrical schematics and drawings not considered proprietary.
- c) The assembly and screening travelers to be used on-line to manufacture the devices supplied to this specification.
- d) Parts and materials list.

3.7 Test Report

A test report is supplied with each shipment of oscillators and includes the following information, as a minimum:

- a) A Certificate of Conformance to all specifications and purchase order requirements. As a minimum, the Certificate of Conformance shall include the following information:
 - Purchase Order Number
 - Applicable Part Number
 - Manufacturer’s Lot Number
 - Lot Date Code
- b) Parts and materials traceability information.
- c) Certificate of crystal sweeping.
- d) Manufacturing lot traveler.
- e) Screening attributes and variables data as applicable.
- f) Quality conformance inspection attributes and variables data as applicable.
- g) Radiographic inspection negatives.

3.8 Engineering Models

Engineering Models are fit, form, and function representative of Flight Models and of commercial construction using commercial parts of same generic type as Flight Models. Completed oscillators are not screened.

NOTES:

This oscillator is offered to meet the specifications above and is not guaranteed to meet any other requirements.

| | | | | |
|--|------------------|--------------------------|------------------------------------|----------|
| Q-TECH Corporation 10150 W. Jefferson Blvd. Culver City, CA 90232 | SIZE A | CAGE NO. 51774 | QT811 and QT812 Square-Wave | REV. |
| | | | Sheet 6 of 8 | A |

■ **PART NUMBER GENERATION**

Engineering Models are designated by adding "E" in front of the part number.

| SERIES | Output type and supply voltage | SYMMETRY | TEMPERATURE RANGE (°C) | STABILITY (Overall) | FREQUENCY (MHz) | External Tuning |
|------------------------|--------------------------------|---------------------------|------------------------|---------------------|---------------------------------------|----------------------|
| QT81: 24 Pin Flat Pack | 1. HCMOS....5.0V | A: 40%...60% | N: 0...+50..... | ±1 ppm | 2.000...90.000 (See note 1) | X: No tuning |
| | 2. HCMOS....3.3V | T: (See note 2) | P: 0...+70..... | ±1 ppm | | R: External resistor |
| | | | Q: 0...+70..... | ±2 ppm | | V: External voltage |
| | | | R: 0...+70..... | ±5 ppm | | |
| | | | U: -20...+70..... | ±1 ppm | | |
| | | | V: -20...+70..... | ±2 ppm | | |
| | | | W:-20...+70..... | ±5 ppm | | |
| | | | X: -40...+85..... | ±4 ppm | | |
| | | | Y: -40...+85..... | ±5 ppm | | |
| | | | Z: -40...+85..... | ±10 ppm | | |
| | | (See note 1 below) | | | | |

- Variations from standard specification are available, please contact factory.
- 45/55 Symmetry Contact factory for options available.

EXAMPLE: The QT812AU-50.000000-R would be a HF TCXO, 24 pin SMD flat pack, HCMOS 3.3 volts, 40/60 symmetry, stability ±1 ppm over -20...+70°C, @ 50 MHz with external tuning via external resistor

■ **RECOMMENDED ELECTRICAL TEST DIAGRAM**

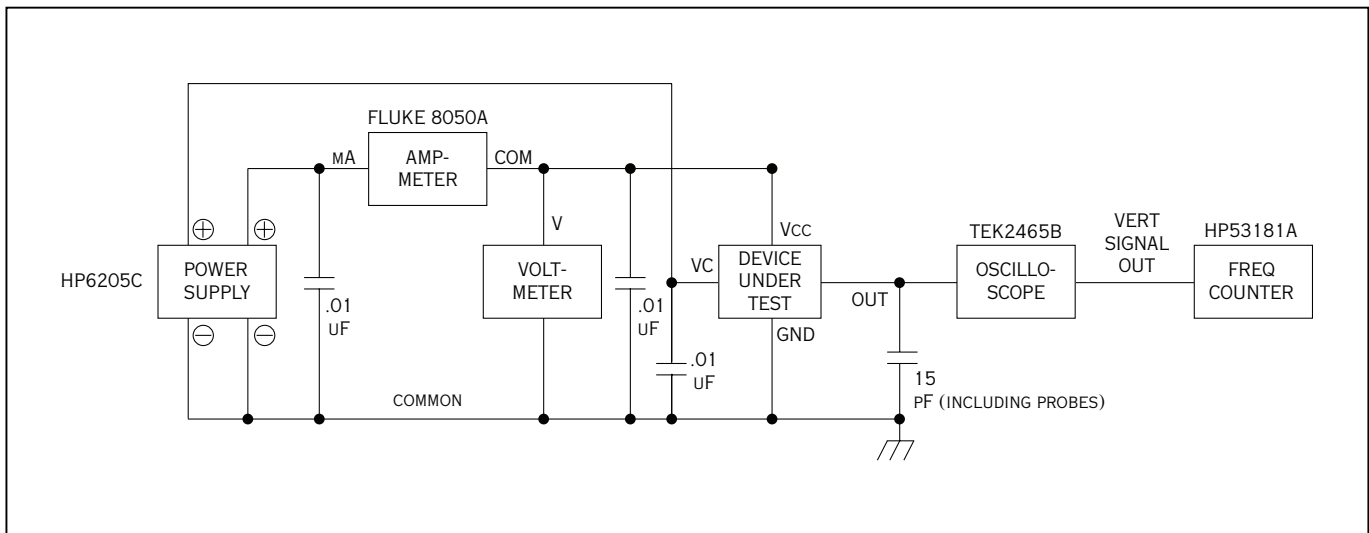

Q-TECH Corporation
10150 W. Jefferson Blvd.
Culver City, CA 90232

SIZE
A

CAGE NO.
51774

QT811 and QT812 Square-Wave

Sheet 7 of 8

REV.

A

FIGURE 1 INTERFACE CONTROL DRAWING

24 Pin Flat Pak

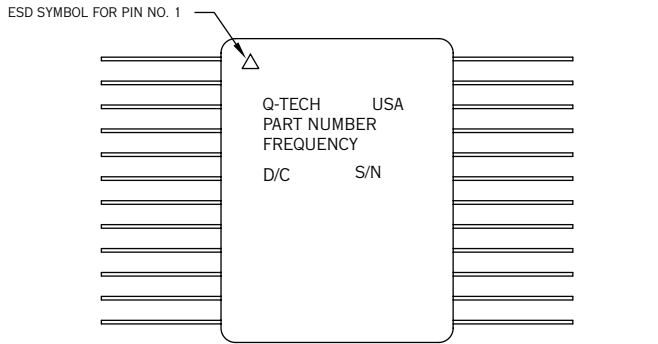

| PIN NO. | DESIGNATION |
|---------|---|
| 1 | External Frequency Adjustment (when specified) |
| 2 - 11 | NC |
| 12 | Ground/Case |
| 13 | RF Output |
| 14 - 23 | NC |
| 24 | Supply Voltage |

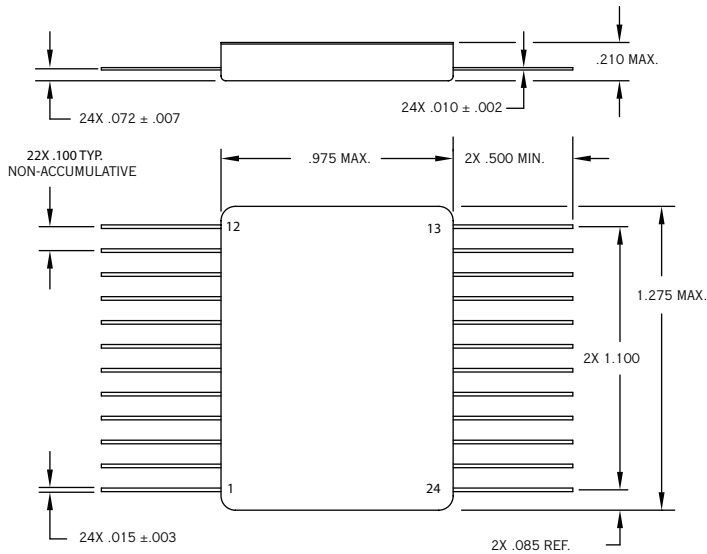

NOTES:

- Dimensions are in inches.
- Lead numbers are for reference only and are not marked on the unit.
- A triangle symbol is marked on the corner of the package to indicate Pin 1
- All pins with NC function may not be connected as external tie or connections (Pins may be connected internally).

Q-TECH Corporation
10150 W. Jefferson Blvd.
Culver City, CA 90232

SIZE
A

CAGE NO.
51774

QT811 and QT812 Square-Wave

Sheet 8 of 8

REV.

A